

DIY ZigBee CCT Light Strip Kit

09.ZGDIYCCTKIT.04282



Important: Read All Instructions Prior to Installation

Function introduction

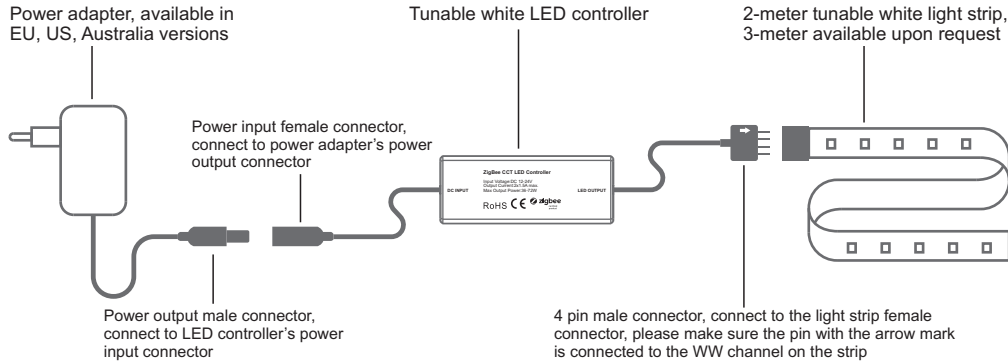

Power Adapter Data

Input Voltage	Output Voltage	Output Current	Output Power	Output Type
100-240VAC, 50/60Hz	24VDC	1.5A	36W	Constant voltage

Tunable White LED Controller Data

Input Voltage	Output Current	Output Power	Output Type	Dimension (LxWxH)
12/24VDC	2CH, 1.5A/CH	36W@12V, 72W@24V	Constant voltage	84x20x14mm

- DIY Zigbee tunable white light strip kit based on latest ZigBee 3.0 protocol
- Power adapter, tunable white LED controller, tunable white strip all included
- Power adapter for different countries available: EU, US, Australia etc.
- Plug and Play, no wiring required
- Place anywhere and bend to any shape, free to shape your lighting style
- Enables to control ON/OFF, light intensity and CCT of connected CCT LED lights
- ZigBee end device that supports Touchlink commissioning
- Can directly pair to a compatible ZigBee remote via Touchlink without coordinator
- Supports self-forming zigbee network without coordinator
- Enables to add devices to the self-formed zigbee network
- Supports find and bind mode to bind a ZigBee remote
- Supports zigbee green power and can bind max. 20 zigbee green power switches
- Compatible with universal ZigBee gateway products
- Compatible with universal CCT ZigBee remotes
- Waterproof grade: IP20

Safety & Warnings

- DO NOT install with power applied to device.
- DO NOT expose the device to moisture.

Operation

1. Plug the connectors correctly and plug the adapter to a socket, then power on.
2. This ZigBee device is a wireless receiver that communicates with a variety of ZigBee compatible systems. This receiver receives and is controlled by wireless radio signals from the compatible ZigBee system.

3. Zigbee Network Pairing through Coordinator or Hub (Added to a Zigbee Network)

- Step 1:** Remove the device from previous zigbee network if it has already been added to, otherwise pairing will fail. Please refer to the part "**Factory Reset Manually**".
- Step 2:** From your ZigBee Controller or hub interface, choose to add lighting device and enter Pairing mode as instructed by the controller.
- Step 3:** Reset power of the device to set it into network pairing mode (connected light flashes twice slowly), 15 seconds timeout, repeat this step.

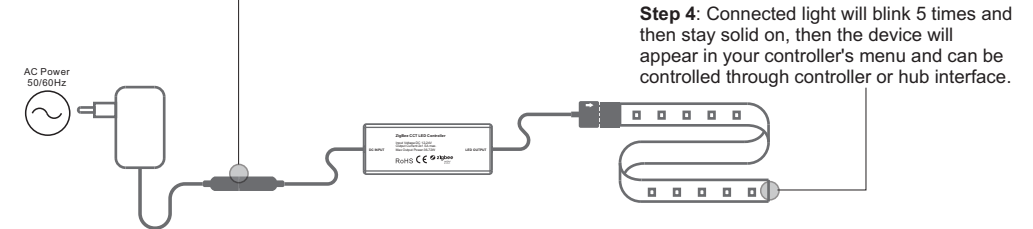

4. TouchLink to a Zigbee Remote

- Step 1: Method 1:** Reset power of the device 4 times to start Touchlink commissioning immediately under any circumstances, 180S timeout, repeat this step.
- Method 2:** Reset power of the device, Touchlink commissioning will start after 15S if it's not added to a zigbee network, 165S timeout. Or start immediately if it's already added to a network, 180S timeout. Once timeout, repeat this step.

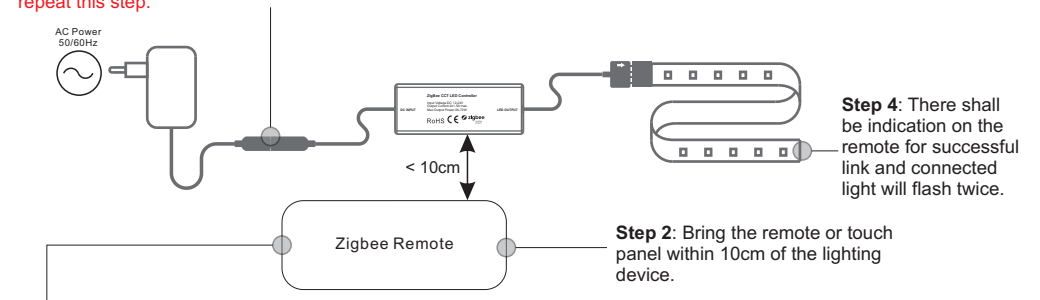

- Step 3:** Set the remote or touch panel into Touchlink commissioning, please refer to corresponding remote or touch panel manual to learn how.

- Note:**
- 1) Directly TouchLink (both not added to a ZigBee network), each device can link with 1 remote.
 - 2) TouchLink after both added to a ZigBee network, each device can link with max. 30 remotes.
 - 3) To control by both gateway and remote, add remote and device to network first then TouchLink.
 - 4) After TouchLink, the device can be controlled by the linked remotes.

5. Removed from a Zigbee Network through Coordinator or Hub Interface

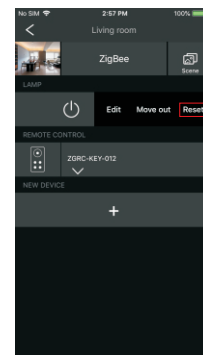

From your ZigBee controller or hub interface, choose to delete or reset the lighting device as instructed. The connected light blinks 3 times to indicate successful reset.

6. Factory Reset Manually

Step 1: Reset power of the device for 5 times continuously.

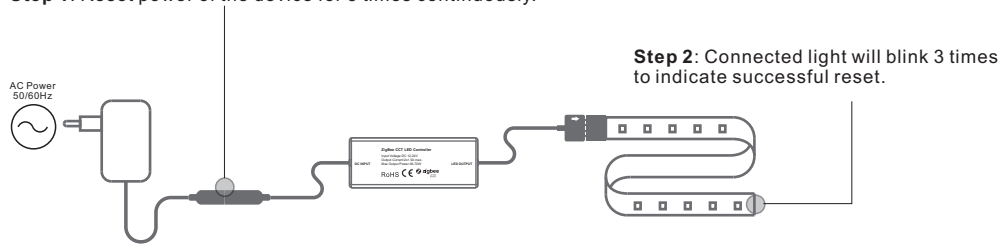

Note: 1) If the device is already at factory default setting, there is no indication when factory reset again.
2) All configuration parameters will be reset after the device is reset or removed from the network.

7. Factory Reset through a Zigbee Remote (Touch Reset)

Note: Make sure the device already added to a network, the remote added to the same one or not added to any network.

Step 1: Reset power of the device to start TouchLink Commissioning, 180 seconds timeout, repeat this step.

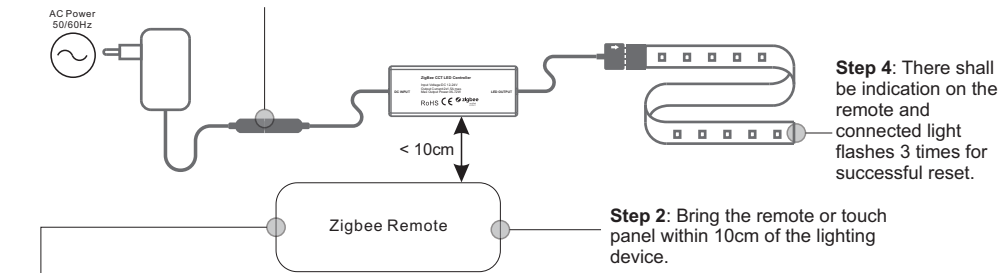

Step 3: Set the remote or touch panel into Touch Reset procedure to reset the device, please refer to corresponding remote or touch panel manual to learn how.

8. Find and Bind Mode

Step 1: Reset power of the device (initiator node) 3 times to start Find and Bind mode (connected light flashes slowly) to find and bind target node, 180 seconds timeout, repeat this step.

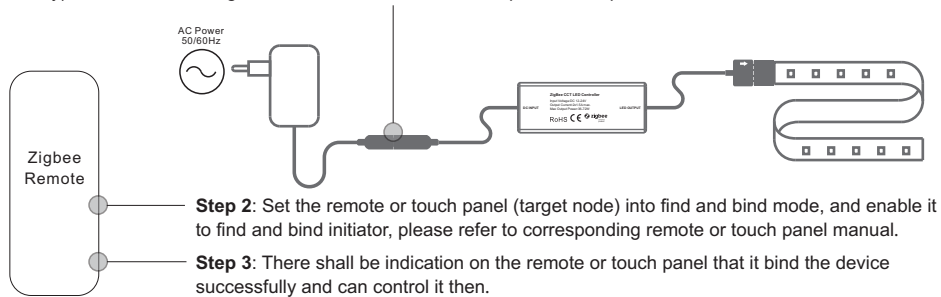

9. Learning to a Zigbee Green Power Switch

Step 1: Reset power of the device 4 times to start Learning mode to GP switch (connected light flashes twice), 180 seconds timeout, repeat this step.

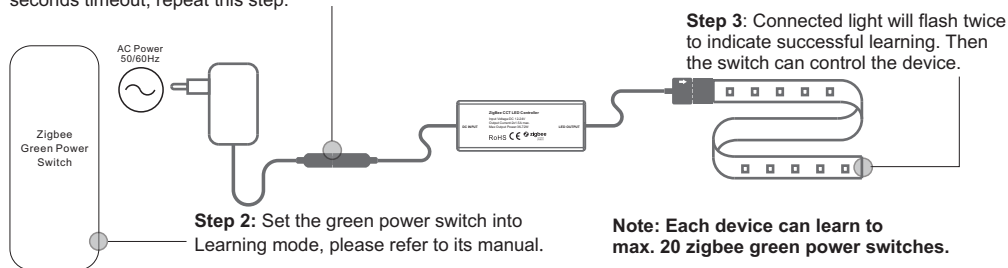

10. Delete Learning to a Zigbee Green Power Switch

Step 1: Reset power of the device 3 times to start delete Learning mode to GP switch (connected light flashes slowly), 180 seconds timeout, repeat the operation.

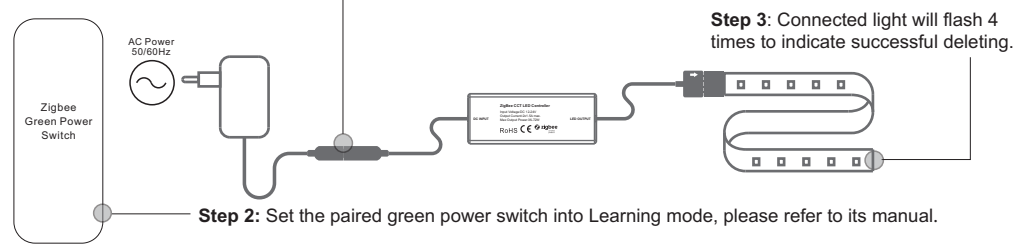

11. Setup a Zigbee Network & Add Other Devices to the Network (No Coordinator Required)

Step 1: Reset power of the device 4 times to enable the device to setup a zigbee network (connected light flashes twice) to discover and add other devices, 180 seconds timeout, repeat this step.

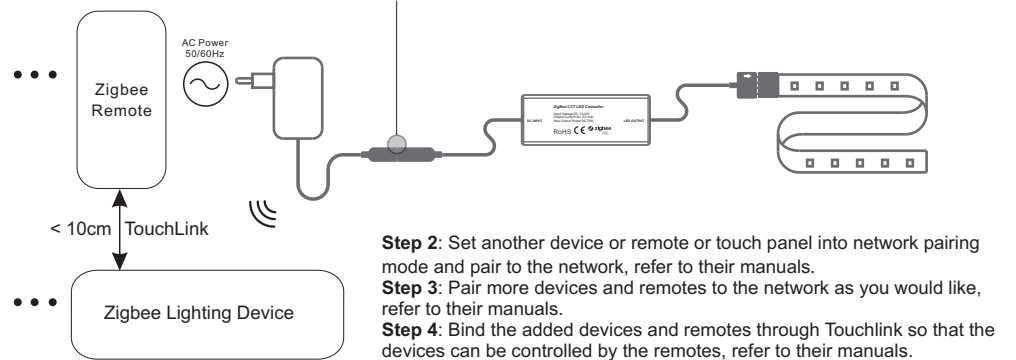

Note: 1) Each added device can link and be controlled by max. 30 added remotes.
2) Each added remote can link and control max. 30 added devices.

12. ZigBee Clusters the device supports are as follows:

Input Clusters

- 0x0000: Basic
- 0x0003: Identify
- 0x0004: Groups
- 0x0005: Scenes
- 0x0006: On/off
- 0x0008: Level Control
- 0x0300: Color Control
- 0x0b05: Diagnostics

Output Clusters

- 0x0019: OTA

13. OTA

The device supports firmware updating through OTA, and will acquire new firmware from zigbee controller or hub every 10 minutes automatically.